

SG14-B5

SHANTUI
VALUE THAT WORKS

MOTOR GRADER
SERIES

ENGINE MODEL	WP6G140E22
GROSS POWER	105kW @ 2200rpm
OPERATING WEIGHT	11600kg

LET'S MAKE
CONSTRUCTION EASIER



SHANTUI CONSTRUCTION MACHINERY CO., LTD.
ADDRESS: No. 58, G327 Highway, Jining City, Shandong, CHINA
TEL: +86-537-2909369 FAX: +86-537-2311219
EMAIL: trade@shantui.com WEB: www.shantui.com



www.shantui.com

SG14-B5 TECHNICAL PARAMETERS

MOTOE GRADER SERIES

SHANTUI
VALUE THAT WORKS

ENGINE

Model	Weichai WP6G140E22
Number of cylinders	6
Type	4-cycle, direct injection, water-cooled
Aspiration	Turbocharged
Bore x stroke	105*130mm
Displacement	6.75L
Gross power	105kW @ 2200rpm
Max. traction	65kN
Max. torque	560N.m @ 1400rpm
Rated fuel consumption	212g/kW.h
Air cleaner	2-stage, dry type

POWER TRAIN

Transmission	Fixed-axis type, electro-hydraulic control
Torque converter	Single-stage, single-phase, three basic elements
Rear axle	"No-Spin" anti-skid differential
Tandem drive	Roller chain. Oscillating angle: ±15°
Tire	13-24PR12
Front axle	Solid bar construction with oscillation about the central mounting pin Oscillating angle: ±15° Tilting angle: ±17°

STEERING

Type	Hydraulic power
Front wheel steering angle	±45°
Articulation angle	±25°
Min. turning radius	6600mm

BRAKES

Service brake	Disc type, foot operated, single circuit, hydraulically actuated on four tandem wheels
Parking brake	Drum type, manually actuated

MOLDBOARD

Type	Hydraulic power, replaceable cutting edges, hardened cutting edges and end bits
Blade width	3660mm
Blade height	615mm
Blade thickness	20mm
Blade tip angle	27~73°
Max. cutting depth	500mm
Max. lifting height	460mm
Max. shoulder reach (left/right)	1700/2000mm
Max. tilting angle (left/right)	±90°

SPEED

Forward, 1-6	5.4\8.3\13.2\20.6\29.6\44km/h
Reverse, 1-3	5.4\13.2\29.6km/h

HYDRAULICS

Tandem pump	Gear pump. 28ml/r
Overflow pressure for working	18MPa

CAPACITIES

Fuel tank	240L
Hydraulic oil tank	85L
Engine crank case	15L
Engine coolant	26L

ELECTRICAL SYSTEM

Battery	2x12V, 105Ah
Alternator	28V, 45A
Starter motor	24V, 6kW

OPERATING WEIGHT

Standard	11600kg
With rear ripper	12850kg
With front blade & rear ripper	13400kg

RIPPER(OPTIONAL)

Ripping depth	254mm
Shank holders	5\9
Shank holder spacing	400/200mm
Working width	1865mm

MIDDLE SCARIFIER(OPTIONAL)

Scarifying depth	210mm
Shank holders	11
Working width	1230mm

FRONT BLADE(OPTIONAL)

Width x Height	2520x880mm
Thickness	12mm
Max. lifting height	520mm
Max. digging depth	18

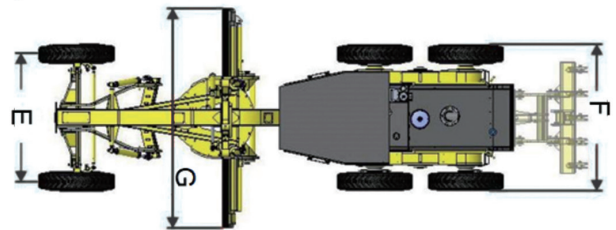
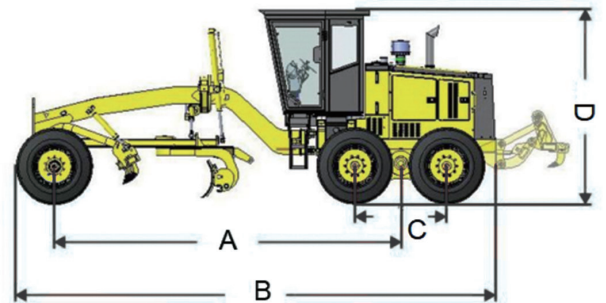

DIMENSIONS

A	Front axle to tandem center	5802mm
B	Overall length: Standard	8036mm
	Overall length: With rear ripper	9310mm
C	Length: Between tandem axles	1540mm
D	Height: Cab	3170mm
E	Tread	2050mm
F	Width: Outside tires	2380mm
G	Blade width	3660mm
H	Minimum ground clearance	430mm