

# SRD08

**SHANTUI**  
VALUE THAT WORKS

ROLLER  
SERIES

ENGINE MODEL	CUMMINS 4BTA3.9-C110-II
GROSS POWER	82kW @ 2200rpm
OPERATING WEIGHT	8000kg

LET'S MAKE  
CONSTRUCTION EASIER



SHANTUI CONSTRUCTION MACHINERY CO., LTD.  
ADDRESS: No. 58, G327 Highway, Jining City, Shandong, CHINA  
TEL: +86-537-2909369 FAX: +86-537-2311219  
EMAIL: trade@shantui.com WEB: www.shantui.com



www.shantui.com

# SRD08 TECHNICAL PARAMETERS TANDEM ROLLER SERIES

**SHANTUI**  
VALUE THAT WORKS

ENGINE	
Model	Cummins 4BTA3.9-C110-II
Number of Cylinders	4
Type	4-cycle, Water-cooled
Aspiration	Turbocharged
Bore X Stroke	102×120mm
Displacement	3.9L
Gross Power	82kW @ 2200rpm
Max. Torque	460N.m @ 1500rpm
Rated Fuel Consumption	224g/kW.h
Air Cleaner	2-stage, Dry Type
POWER TRAIN	
Driving Pump	Variable Piston Pump, 75ml/r
Driving Motor	Variable Piston Motor, High Flow Type, 2812ml/r
Vibration Pump	Variable Piston Pump, 55ml/r
Vibration Motor	Constant Piston Motor, 35ml/r
Max. Grade Ability	35%
DRUM (FRONT/REAR)	
Width	1700mm
Diameter	1050mm
Drum Shell Thickness	17mm
Frequency, High	48Hz
Frequency, Low	42Hz
Amplitude, High	0.75mm
Amplitude, Low	0.35mm
Centrifugal Force, Maximum	82kN
Centrifugal Force, Minimum	40kN
STEERING	
Type	Hydraulic Power, Articulated Steering
Steering Angle	±30°
Oscillating Angle	±10°
Min. Turning Radius	6000mm
BRAKES	
Service Brake	Hydraulic Brake
Parking Brake	Multi-disc Brake
Emergency Brake	Hydraulic Brake
SPEED	
Forward,1-2	0-6.0/0-12.0km/h
Reverse,1-2	0-6.0/0-12.0km/h
CAPACITIES	
Fuel Tank	150L
Hydraulic Oil Tank	130L
Engine Crank Case	9L
Drum	7.5L
Sprinkle Water Tank	600L
Coolant	30L

ELECTRICAL SYSTEM	
Battery	2X12V,105Ah
Alternator	28V, 55A
Starter Motor	24V, 6KW
WEIGHT	
Operating Weight	8000kg
Front Drum Load	4000kg
Rear Drum Load	4000kg
Static Linear Load (Front Drum)	230N/cm
Static Linear Load (Rear Drum)	230N/cm

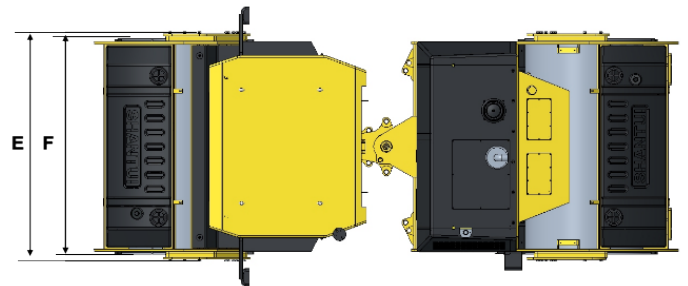
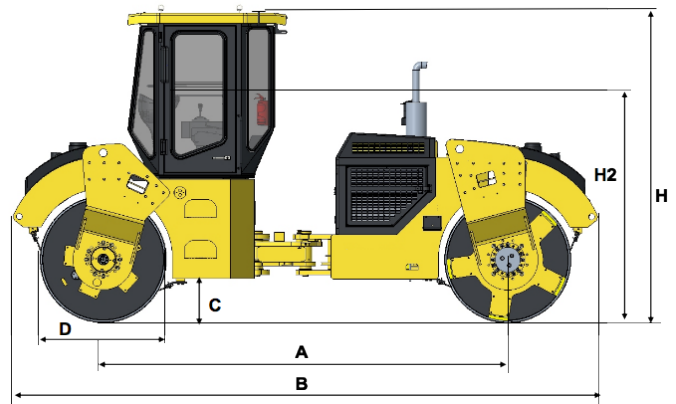

DIMENSIONS	
A	3300mm
B	4380mm
C	320mm
D	1050mm
E	1860mm
F	1700mm
H	2950mm(Cabin)
H2	3100mm(A/C)
	2400mm