

L39-B3

- ▶ Engine model: Weichai WP6G125E22
- ▶ Rated power: 92 kW/2200 rpm
- ▶ Operating weight: 10.8 t

Product features

L39-B3 is an all-new designed 3t long-wheelbase planetary transmission loader product. It's mainly applicable for medium/small-scale aggregate yards, mixing stations, small coal mines, farmlands, pastures, and urban and road constructions. With longer wheelbase, it can features more extensive application scenes.



SHANTUI

VALUE THAT WORKS

L39-B3

Technical specifications:

	Standard Arm	Extended Arm	Long Arm
Overall length	7148mm	7275 mm	7395 mm
Overall width	2518mm	2518 mm	2518 mm
Overall height	3235mm	3235 mm	3235 mm

L39-B3

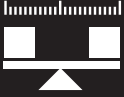
 GENERAL SPECIFICATIONS	Operating weight	10800 kg
	Rated Load	3000 kg
	Bucket capacity	1.8 m ³
	Breakout force	105 kN
	Static tipping load (full turn)	6000 kg
	Dumping height (Standard/Extended/Long)	2875/3057/3200 mm
	Dumping reach (Standard/Extended/Long)	955/906/886 mm

 ENGINE	Engine model	Weichai WP6G125E22
	Type	In-line, water-cooled, 6-cylinder, direct injection, turbocharged
	Rated power	92 kW
	Rated speed	2200 rpm
	Displacement	6.75 L
	Maximum torque	510 N·m
	Minimum fuel consumption	193.8 g/kW·h

 TRAVEL SPEED	Gear	1st	2nd	3rd	4th
	Forward	0~12.5 km/h	0~38 km/h	-	-
	Reverse	0~16.4 km/h	-	-	-

 AXLES AND FINAL DRIVES	DRIVE SYSTEM		Four-wheel drive
	Gradeability		30°
	Maximum traction		110 kN
	BRAKE SYSTEM:	Service brakes	Air over hydraulic disc brakes on 4 wheels
		Parking brake	Manual parking brake
	STEERING SYSTEM:	Type	Articulated type, full-hydraulic power steering
		Maximum steering angle	38° each direction
		Turning Radius to Outside of Tires	5415 mm
		Turning Radius to Outside of Bucket	6036 mm
	TIRES	Type	17.5-25 12PR
		Pattern level	L3
Center distance of tires		1856 mm	
Wheel base		2900 mm	

 HYDRAULIC SYSTEM	Hydraulic cycle time (rated load in bucket)	Lifting time/ Lifting, dumping and lowering	4.8/8.9 s

OVERALL DIMENSIONS

▶ THE SPECIFICATIONS ARE SUBJECT TO CHANGE WITHOUT NOTICE. THE PICTURES MAY INCLUDE OPTIONS. THE ACTUAL COLOR & APPEARANCE OF THE PRODUCT MAY DIFFER FROM WHAT IS SHOWN.

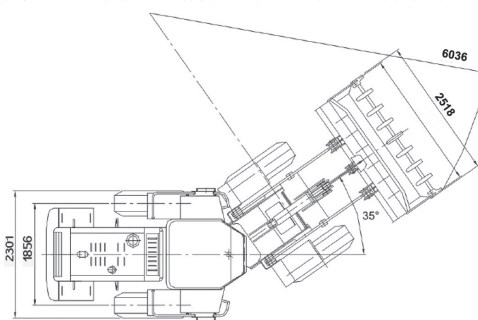
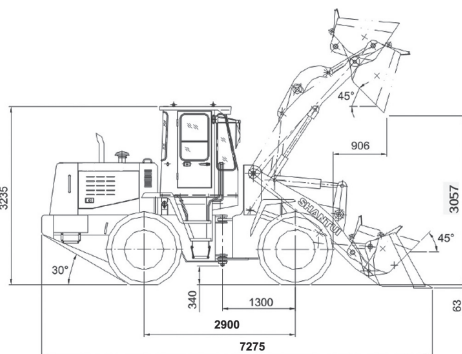

Cebu 3in1 Marketing Corp

CEBU
 # 88 Block 4, North Reclamation Area,
 Subangdaku, Mandaue City,
 Cebu Philippines, 6014
 Tel.: + 6332 346-2297; 346-0171;
 343-8608; 422-3789
 Fax: +6332 346-2295
 Mobile: +63 977-811-9796

DAVAO
 8 Dacudao Ave., Davao City
 Email: davao.sales@3in1group.ph
 Tel.: 082 322-6514
 Mobile: +63 917-148-4628

MANILA
 107 Roosevelt Ave.,
 SFDM Brgy. Paraiso, Quezon City
 Tel.: +632 426-6000
 Email: cyr.gella@3in1group.ph
 Mobile: +63 917-712-5765